

REFERENCES

1. Manual of Standard Procedures - Gliding Federation of Australia.
 2. OSTIV Airworthiness Requirements for Sailplanes, December 1966
 3. Irving, F. G. and Vernon, C.O., "The Durability of Glues Used in Glider Construction," 10th OSTIV Congress, England 1965, OSTIV Publication VIII.
 4. Irving, F.G., "The Airworthiness of Wooden Aircraft," Sailplane and Gliding, Vol. 17, No. 1, 1966.
 5. Obee, K. R., "The Fatigue Life of Wooden Gliders," 9th OSTIV Congress, Argentina 1963, OSTIV Publication VII.
 6. Chernov, V.V., "Results of Research in the Field of Structural Strength Limits for Sporting Gliders," 10th OSTIV Congress, England 1965, OSTIV Publication VIII.
 7. Shenstone, B.S. and Wilkinson, K.G., "The World's Sailplanes, Vol. II," January 1963.
 8. Payne, A.O., "Determination of the Fatigue Resistance of Aircraft Wings by Full-Scale Testing," Full-Scale Testing of Aircraft Structures, pp. 76-132, Pergamon Press, London 1961.
 9. Graff, D.G., "Proof Loading of 'Zephyrus' Gliding Wing," Tech Memo Sm/ARL Department of Supply, Aeronautical Research Laboratories, Melbourne.
-
-

A LOW SPEED SAILPLANE FOR RESEARCH

D. F. Farrar, Jr., Nashville, Tennessee, U.S.A.

Presented at the 12th OSTIV Congress, July 1970
Alpine, Texas, U.S.A.

A few years ago we entered into a research project at Vanderbilt University to study the flight characteristics of several species of gliding birds, namely the Black Vulture, Turkey Vulture, Red Tailed Hawk, etc.

A portion of the flight measurement was done by following a free-flying bird in a quiescent atmosphere with a sailplane. The altitude and velocity of the bird were matched at frequent intervals by the sailplane and reported to the ground recorder via radio. Analysis of the data collected by many flights provided the information required to plot the polar diagram of velocity versus sinking speed for the

bird. This method proved to be successful and reliable, however it was limited by the fact that the stalling speed of the sailplane, namely 30 mph, was so high that only the high-speed portion of the bird's polar diagram could be measured. The sailplane which is the subject of this paper was designed to more nearly match the speed range of the bird. Flight tests to date indicate that this goal has been achieved.

The original primary design specification for the subject sailplane was a stalling speed of 20 mph. In addition, the flight performance was to be at least equal to that of the birds we were measuring and a load factor of 6 was to be main-

tained at 60 mph. This last requirement would ensure a degree of durability and allow for towing with the airplanes available. The complete original specifications were:

Wing Span	- 61 feet
Wing Area	- 230 sq ft
Airfoil Profile	- Wortmann FX-05-H-126
Gross Weight	- 300 lb

Estimated performance with these specifications was:

Stall Speed	- 20.5 mph
Max L/D	- 33
Min Sink	- 1.0 ft/sec
Load Factor	- 6 G at 60 mph design velocity

Unfortunately some of the original specifications were not met in the actual construction and the performance figures were therefore altered. The maximum deviation from the specifications was in the gross weight which increased from 300 lb to 356 lb. The effect of this change is to increase the stall speed and the sinking speed and to lower the load factor. Fortunately, all these changes are relatively small.

This sailplane was completed in September 1969 and successfully flown throughout the preliminary test period. Precise measurements of the performance have not been completed; however, indications to date seem to substantiate the calculated performance figures.

The final configuration of the sailplane was altered from the initial plan. The weight of the tail assembly, its controls and supporting structure was more than planned, causing a shift in the center of gravity toward the rear. To counteract this change, the pilot seat was moved forward and the wing was moved aft so that the wing leading edge is now behind the pilot's head. This new arrangement made it possible to lower the position of the wing about 6 in. and thereby reduce the total frontal area as shown in Fig. 1 where (A) is the original and (B) is the final profile.

The fuselage is circular in cross section at all stations and is built of 1/8 in. balsa wood covered on both sides with

fiberglass cloth and epoxy resin. The shell is stiffened with balsa rings of 1/2 in. sq. cross section, wrapped with fiberglass cloth and epoxy resin, spaced 2 ft apart throughout the aft section of the fuselage. Additional rings were used adjacent to the wing support, pilot's seat, and landing skid structures.

The wing support of 5/8 in. diameter aluminum tubing extends to the bottom of the fuselage and forward to take the landing skid and pilot seat loads. The tubular structure is bonded to the fuselage shell with fiberglass cloth and epoxy resin and is bolted to the internal skid stringers.

The canopy is made from two pieces of 1/16 in. plexiglass fastened to a frame of aluminum tubing hinged on the left side of the fuselage.

The wing is composed of a built-up aluminum spar; ribs of plywood and spruce; leading edge D tube of plywood and covering of plastic film. The wing was built in three sections: a 25-ft center section and two 18-ft tip sections. The center section has a constant chord of 4-1/2 ft. The out sections taper from 4-1/2 ft to 2 ft chord at the tip.

The wing spar, shown in Fig. 2, is composed of a web of 0.020 in. thick 7075-T6 aluminum to which four angles of the same alloy 1/2 in. x 1/2 in. x 0.065 in. are riveted to form the upper and lower flanges. The flange thickness is increased toward the center of the wing by adding 1 in. x 0.065 in. cover plates. Four cover plates are required to carry the large bending moment near the center of the wing. The number of cover plates required decreases to zero 10 ft from the center of the spar. The flange is composed of the aluminum angles alone for the remainder of the wing span. The spar web is stiffened by bent aluminum angles riveted from flange to flange and to the web. These angles are spaced 6 in. apart on the forward side of the spar and 12 in. apart on the aft side of the spar. The ribs are riveted to these angles. The spar depth is less than the wing thickness so that both spar flanges are perpendicular to the web and the rib cap strips extend over the spar flanges. The spaces between the ribs outside the flanges is filled with

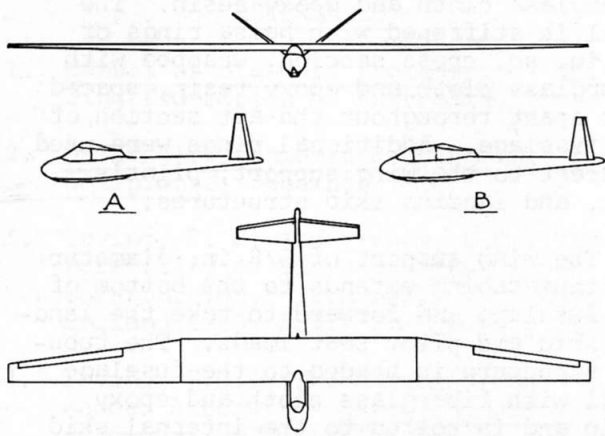

FIGURE 1

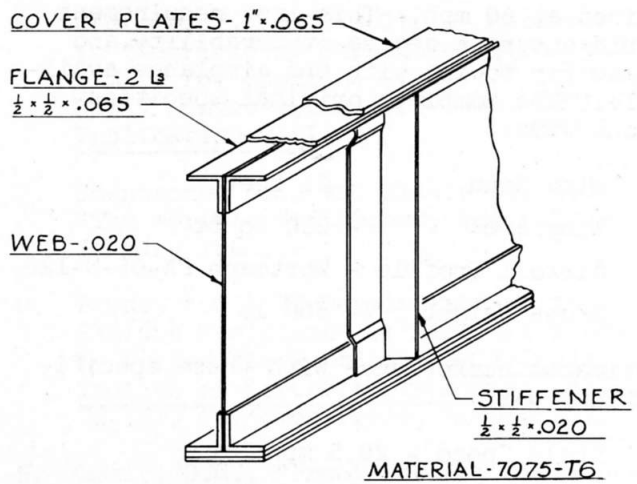

FIGURE 2. WING SPAR CONSTRUCTION

FIGURE 3

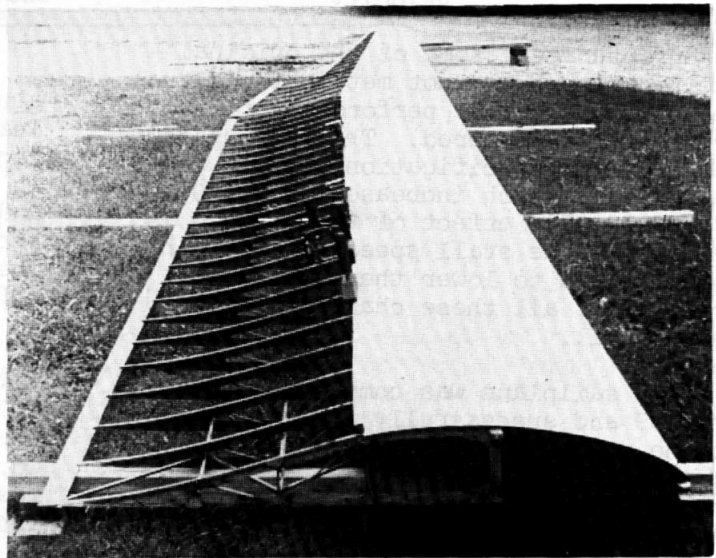
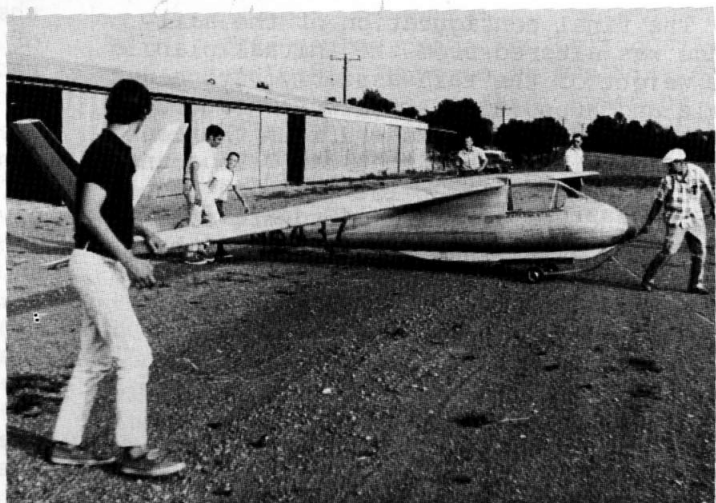

FIGURE 4



a wood strip glued to the spar flange and shaped to the contour of the rib. The plywood nose covering 1 mm birch is glued to the ribs and these filler strips.

The ribs are formed by a 1 mm birch plywood outline, 1 in. wide to which 1/4 in. square spruce cap strips and 1/4 in. x 1/8 in. spruce struts are glued. Small gussets of 1 mm plywood are glued across the spruce joints on the outer side of the ribs. Each rib was composed of two pieces, one forward and one aft of the spar, joined on assembly in the jig with a spruce splice above and below the spar.

The trailing edge of the wing is formed of two pieces of 1 mm birch plywood, each 2 in. wide, being glued together at the aft edge and separated by a spruce filler strip between ribs at its forward edge. Due to the contour of this airfoil, the trailing edge is very thin and fragile.

The wing and tail surfaces are covered with white 100 gauge Tedlar, a DuPont polyvinyl fluoride film similar to Mylar, but with better weathering properties. The Tedlar has been treated on both sides by the manufacturer so that glue, ink, etc., will stick to it firmly. This covering is glued in place on the structure with flexible contact cement which is also used to make joints between pieces of the plastic film. While it has less tear strength and puncture resistance than lightweight fabric, the Tedlar has been entirely satisfactory as a covering material and its use has saved a number of pounds weight.

The 110 deg V tail surfaces are of the all-moving type with 20 percent geared trailing edge flap which moves through twice the angle of the main surface. A spruce and plywood box spar contains the needle bearings on which the surface is mounted. Two steel tubes 1-1/4 in. in diameter from the supports and axles for these surfaces. The thickness of the tubes tapers from 0.058 in. at the center to 0.032 in. at the ends. The tail surface ribs are 1/4 in. balsa wood with fiberglass-resin on each side. The 20 percent chord tabs are of 1/16 in. balsa wood over a beaded foam plastic core, covered with a thin silk fabric attached with airplane dope. These tabs are entirely satisfactory and weigh half as much as those made

from balsa ribs covered entirely with 1 mm birch plywood.

The landing skid was made quite large to provide protection for the underside of the fuselage. The skid is made from beaded foam plastic covered with fiberglass-resin and provided with a birch plywood rubbing shoe on the bottom. The lower surface of the skid is almost straight for the center 4 ft and makes for very smooth landings. The tail skid is of the same type construction as the main landing skid.

The control system is built of 5/8 in. diameter aluminum push-pull tubes and aluminum bell cranks. The ailerons move in a differential fashion 5 deg down and 15 deg up in order to minimize the adverse yaw. Aileron control is adequate. Response of the machine to all other control movements is positive and rapid.

From the pilot's point of view, flight in this glider is a new experience. On release from the towplane, the velocity is reduced to about 30 mph and everything seems to stop moving. Vertical descent occurs at a very slow rate. On one flight, release was at 3300 ft above ground and a series of maneuvers was performed including sideslips in both directions, velocity increases to 50 mph, tight turns in both directions, figure 8 turns, etc. When the pilot finished the planned maneuvers, 2000 ft of altitude remained so additional sideslips, etc., were performed. Total duration of this flight from time of release was 30 minutes, making the average rate of sink 1.77 ft per sec. There was no noticeable atmospheric lift or sink during this flight. It is my opinion, based upon this flight and others, that the minimum rate of sink will be very near 1.0 ft per sec, when it is accurately measured. The stalling speed has not been measured; however, the machine touches down, still flying at 25 mph. The true stalling speed will be very close to 23 mph.

This sailplane gives every indication that it will be suitable for its intended purpose in the bird flight study program and has essentially met its design specifications. It is expected that this machine will prove to be useful in other studies than the bird flight project, such as a low-speed probe in studies of atmospheric movement. We hope that its life will also prove to be productive.