

Progress in Home-Built Sailplanes

Gary Sunderland, M.I.E. Australia

Presented at the XVIIth OSTIV CONGRESS
Paderborn, Germany
May 1981

By way of introduction, the author is a mechanical engineer by training but an aeronautical engineer by vocation. Twenty years experience with home-built aircraft, first as a Gliding Federation Airworthiness Inspector and a lecturer at the National Gliding School, are additional to ten years as an Airworthiness Engineer with a Regional Airworthiness Section of the Department of Transport, Australia.

This Section is responsible for the certification of new aircraft designs, a major proportion of these being sailplanes, plus the airworthiness control of aircraft in the "Amateur Category". There is no Experimental category in Australia and aircraft designs flying in other than a full C of A in an overseas country may be cleared for amateur construction on the basis of the proven "safe-history" of a certain number of the type having flown a certain number of hours without incident. The building of each aircraft is then closely controlled by the Department. Following an initial fifty hours of flying on a permit, the aircraft is then certificated in the "Amateur" category with no area or other restrictions. Local designs are, however, required to comply with the full certification process.

Until recently, all sailplanes have utilized normal wood or metal construction techniques. Amateur designs universally have adopted the materials used in sailplane factory construction for the previous forty years. This conservatism contrasts to the amateur-built aeroplane movement which is not only utilizing composite materials, but has developed many new construction techniques to suit home-builders.

While factory construction of sailplanes has changed, within a short period, to glass reinforced plastics with the attendant advantages of improved surface finish, no similar change occurred for amateur designs. This is most likely due to the problems of quality control and the resulting variable and unknown properties of composite materials.

Consideration of all the factors involved showed that there was no particular advantage to be gained in utilizing glass plastics for the wing spar, rear fuselage, or fin of a sailplane. In fact, these major structural components are more suited to construction from materials having a higher stiffness/weight ratio. This led to consideration of an amateur-built sailplane design utilizing mixed construction with metal and/or wood basic structure married to a smooth exterior of non-structural or semi-structural fibreglass.

GENESIS

Many years ago I owned a Schneider ES60 Boomerang. This was exchanged for a house and a part share in a Glasflugel H201B "Libelle". However, I was determined to have "My Own Aircraft" number two. The available finances dictated that I would have to build it myself.

As the years went by and the project absorbed more and more time and energy, the name changed to "My Own B Aircraft", mainly from exasperation at the seemingly insurmountable problems involved in the design and construction. I am led to understand that the "B" term is not translatable into any language other than English.

Of the sailplane designs available at that time, most were judged lacking in performance and appeal.

An interest in contest flying meant I desired a reasonable high performance machine, particularly as a minimum three or four year building time had to be considered.

At the time, this narrowed the choice down to the Neukim "Elfe" kit, which was too expensive, and the Schreder HP-16, with its bonded metal construction which did not recommend itself to me. When I was a design engineer at Aeronautical Research Laboratories I experienced sufficient bonded metal joint failures to last several lifetimes.

It occurred to me that it would be possible to design a suitable glider by adopting the proven construction methods used in certain amateur category aeroplanes, with slight improvements.

The MOBA-2 project therefore had two goals which were:

- (a) To experiment with and develop new methods of sailplane construction suited to amateur builders.
- (b) To satisfy a personal requirement for a high-performance sailplane.

FIRST THOUGHTS

Design of what was to be called the MOBA 2A 15 meter sailplane started in 1970 and progressed slowly. The design adopted the so-called 1974 Standard Class rules which permitted simple flaps to be fitted.

To be worthwhile, the MOBA 2A had to be better than the Open Libelle I was flying. A difficult task! This forced considerations of increasing the aspect ratio and wing loading relative to that sailplane. The resulting small wing area was also less work to build and helped to minimize the empty weight. At this time, the main difficulty was to find what materials were available from far-away USA supply houses. It seems that not all that is in MK-HDBK-5 and Bruhn is available...certainly not to prospective sailplane builders. A general shortage of aircraft specification aluminum in 1971-1973 did not help the process. I gave up any ideas of using convenient extrusions and

settled on a built-up but simple three-piece box spar using 2024 sheet and angle.

The Thorpe T-18 amateur built aeroplane uses a technique of "jigless" metal construction which provides a method whereby a sheet metal airframe may be constructed to a high degree of accuracy (Ref. 1). My intention was to adapt this method to a sailplane design.

This system of manufacture can be assisted by the use of blind fastening monel "pop" rivets which permit the closure of small box sections. Figure 1 shows the relative shear strengths of various rivet types. Pop rivets have been proven in Australia in the certificated Victa "Airtourer" and in many amateur-built aeroplanes. They can suffer from loosening under conditions of vibration and corrosion but are well suited to sailplane construction if zinc-chromate wet assembly techniques are adopted.

From the Beatty-Johl BJ-3 sailplane came the idea of using foam and glass fibre to obtain a good surface smoothness (Ref. 2). Figure 2 shows that a suitable disposition of the spar booms may be achieved. Thus, a high cantilever ratio may be obtained and a resulting high aspect ratio, even with a comparatively thin profile like the Wortmann FX67-K-150.

A major design problem was the attachment of the wing tips to the center wing section. Slingsby "Skylark" type fittings were clearly out of the question and something like a glass fibre sailplane spar joint was obviously the way to go. A straight copy in metal looked complicated and inefficient. The final four point joint is a simple solution. The details are shown in Figure 3.

Once the outlines of the basic metal "skeleton" were decided it was then just a question of fleshing out the contours with foam and glass fibre to obtain an aerodynamic shape. Refer to Figure 4.

Not all design features were borrowed. The desire to avoid the usual problems with canopy fit and leakage, plus the need to somehow join the cockpit fairing separately, led to the sliding nose feature.

Similarly, the wide fuselage begat the triangulated and efficient main undercarriage truss.

"AG" 13 METER DESIGN CONTEST

In December 1970, the Australian Gliding Magazine announced their design contest for a home-built sailplane of not more than 13 meters span (Ref. 3).

The winner's prize was to be:

- (1) \$1000 cash
- (2) The winning design was to be built by a glider maintenance firm and presented to the contestant.
- (3) Type certification of the design was to be obtained from the authorities for the contestant.

This contest led to the parallel design of the MOBA 2A and a 13 meter version, the MOBA 2B. The redesign and submissions to the contest took the best part of two years, during which time the MOBA 2B became one of the finalists for the prize. Finally the judges abandoned the contest without deciding a winner, which was most disappointing. No reason for this decision was provided but it may be suspected that the judges were embarrassed by the most generous prize - to build and complete the certification of the winning design.

MOBA 2C

The design of the 15 meter MOBA 2C, finally constructed by the author, followed closely the earlier two versions (Figure 5) but with an enlarged fin and a fabric covered rudder in place of the original metal covered design. BCAR Section E was chosen as the design code in preference to OSTIVAR, mainly because the latter is not yet recognized in Australia, but also because the BCAR-E is a simpler and less onerous code for an amateur to use.

The conservative stress analysis of the wing and fuselage of MOBA 2C assumed that the metal structure takes all bending and torsion loads. Limit and ultimate factors of +4 and +6 respectively were established for "non-cloud flying" category certification. Additional calculations, taking into account the bending and torsion

reinforcement available from the glass cloth, show that the structure has a minimum reserve factor of at least 1.3 over design calculation. In other words, the glider is actually as strong as gliders in the "cloud-flying" category and therefore a valid comparison of structural weights may be carried out with other sailplanes.

The design empty weight was exceeded mainly due to the amount of filler required in profiling the wing. The final weight breakdown and a comparison of empty weights is shown in Figure 6.

Actual building showed the practicality of the "jigless" metal construction technique. The method of obtaining an accurate wing profile was also shown to be practical but rather laborious. The method has been fully described previously in Refs. 4 and 5, but in summary consists of bolting accurate plywood ribs to the spar. The space between the ribs is filled with urethane foam blocks glued in and sanded back to profile. The whole is then covered with two layers of plain weave marine grade fiberglass cloth impregnated with epoxy resin. A similar construction method is used for the center fuselage fairing and tailplane, while the sliding nose cone is a glass balsa sandwich. All of the airframe building was carried out by the author alone, without assistance.

Construction time was six years and the first flight occurred Dec. 12, 1979. Under normal circumstances this building time could be halved.

FLIGHT RESULTS

The glider now has over 130 hours flight time of which 30 hours involved certification flight testing and 80 hours contest flying.

Flight characteristics are generally docile and only a few minor modifications were required to complete certification.

The novel sliding nose cone feature has proved to be quite practical. The canopy is normally closed but can be opened in flight to provide clear vision. Opening loads in flight at speeds up to 80 knots are not

measurably more than with the glider at rest. There are no changes in flight characteristics with the canopy open 50mm, apart from a slight increase in noise and stall buffet.

No performance measurements have been undertaken to date but, from flight comparison with other sailplanes, the calculated performance seems to have been achieved. Despite the high wing loading, the minimum sink and soaring performance is good due to the low span loading.

Actual cross country performance is somewhere between modern Standard Class and 15 Meter Class sailplanes. The glide performance is about equal to the 15 Meter sailplanes up to 80 knots and then rapidly falls behind because the flaps and ailerons do not provide for negative adjustments.

Had the proposed 1974 Standard Class rules been introduced as originally planned, the MOBA 2C sailplane would have remained competitive. Under the existing rules, the MOBA 2C has to fly in 15 Meter Class at a performance disadvantage.

CONCLUSIONS

The MOBA 2C project has demonstrated a technique whereby an amateur constructor can produce a "one-off" sailplane without jigs and molds and with only simple hand tools.

The details of the structure could be adapted by a designer to produce any class of sailplane: Standard, 15 Meter, or Open.

From the experience gained, I would recommend that a sandwich construction with PVC foam would be lighter and more accurate than the urethane foam blocks used in MOBA 2C.

The metal box spar structure would seem to be well suited to incorporation in a variable geometry sailplane as previously demonstrated by Pat Beatty. Fig. 7 shows a possible development of MOBA 2C with variable chord for the 15 Meter Racing Class. Apart from the time and cost to complete such a design, an adverse consideration is the possibility of the 15 Meter rules being changed in the interim.

As demonstrated above, the amateur designer/builder is at a considerable disadvantage in competing with the professional designers and sailplane factories where changes in the rules occur while the amateur project is underway.

THE 13 METER CLASS

At present there is no contest classification for amateur designs or home-built sailplanes in general.

What the soaring movement really needs are sailplanes to help fill the void between training and national competition, to fill the requirements of the recreational pilot. A low priced, easy-to-fly sailplane can attract a good number of soaring pilots. Many of these pilots are after soaring badges and some want to fly friendly competition in regattas or sport class competition, but most want to get the maximum enjoyment from the sport at a reasonable cost and maximum safety. This requirement is the same as the original concept of the International Standard Class of 1956. The Standard Class has developed into expensive and sophisticated sailplanes that are a far cry from the original concept. They are also too heavy! My wife and I cannot rig a modern glass fibre Standard Class machine because of the weight of the wing panels. The introduction of carbon fiber structure is not a solution as we could never afford to own such expensive sailplanes.

The economics of factory production make it difficult to manufacture such a 13 meter sailplane, mainly because it has to be sold in competition with second-hand Standard Class gliders. The new glider class must be home-built.

It would be a considerable boost to amateur-building and I believe a step of great and lasting value to the soaring movement as a whole, if there were an internationally recognized class for amateur-built sailplanes. Small sailboats which can be home-built have been responsible for the tremendous growth in yachting as a popular sport. A special class would also act to

encourage the many amateur designers in the world.

In my view, it is not necessary or desirable to conduct a design contest to select a particular type to represent the class. On the contrary, it would be better to encourage as many designers as possible to complete aircraft and enter them in National 13 meter class competitions. At some stage it may be even considered worthwhile to conduct International 13 Meter Class competitions, but this would not be necessary at the start. The object of the National 13 Meter contests would be both to encourage home-building and introduce newcomers to contest flying.

A "Home-Built" class already exists in embryo with such sailplanes as the "Woodstock", Monett "Moneri", Pascoe EP-2 and "Duster", which are all of less than 13 meters span and designed for home-construction.

The following basic rules are suggested:

1. Span not more than 13 meters
2. Fixed wheel
3. Dive brakes, spoilers or plain flaps only allowed
4. Home-built...to be built from plans or a kit with not less than 51% of construction by the builder.

In the USA, Mr. Stan Hall has called for the development of modern home-built designs (Ref. 6).

I cannot agree with the SSA contest aim of promoting a hybrid/powered sailplane/ultralight in the one aircraft. The result is likely to be a low powered and unreliable small aeroplane, hardly likely to advance the cause of soaring.

However, an orthodox 13 meter sailplane is well within the state of the art and the capabilities of most designers. It would have flight characteristics not too dissimilar from two-seater training gliders and bridge the gap to the more expensive Standard Class machines. Perhaps a very clever designer could also add a small engine without too many other disadvantages.

I am sure that, if there were an International sanctioned home-built class, designers throughout the world, both amateur and professional, would eagerly rise to the challenge and develop even more efficient and safe gliders for home-builders.

In these days of rapidly increasing costs, the value of a new class of comparatively simple, cheap and light sailplanes would be of great benefit.

REFERENCES

- [1] Thorp, John W., "Building the T-18," Sport Aviation, May 1962.
- [2] Beatty, Pat, and Johl, Fritz, Soaring, May 1968.
- [3] "Sailplane Design Competition," Australian Gliding, June 1972,
- [4] Sunderland, Gary, "Progress Report - Project MOBA 2C," Australian Gliding, May 1978.
- [5] Hall, Stan, "Homebuilder's Hall," Soaring, June 1978.
- [6] Hall, Stan, "Homebuilding - Soaring's Sleeping Giant?," Proceedings of the 1980 SSA National Soaring Convention.

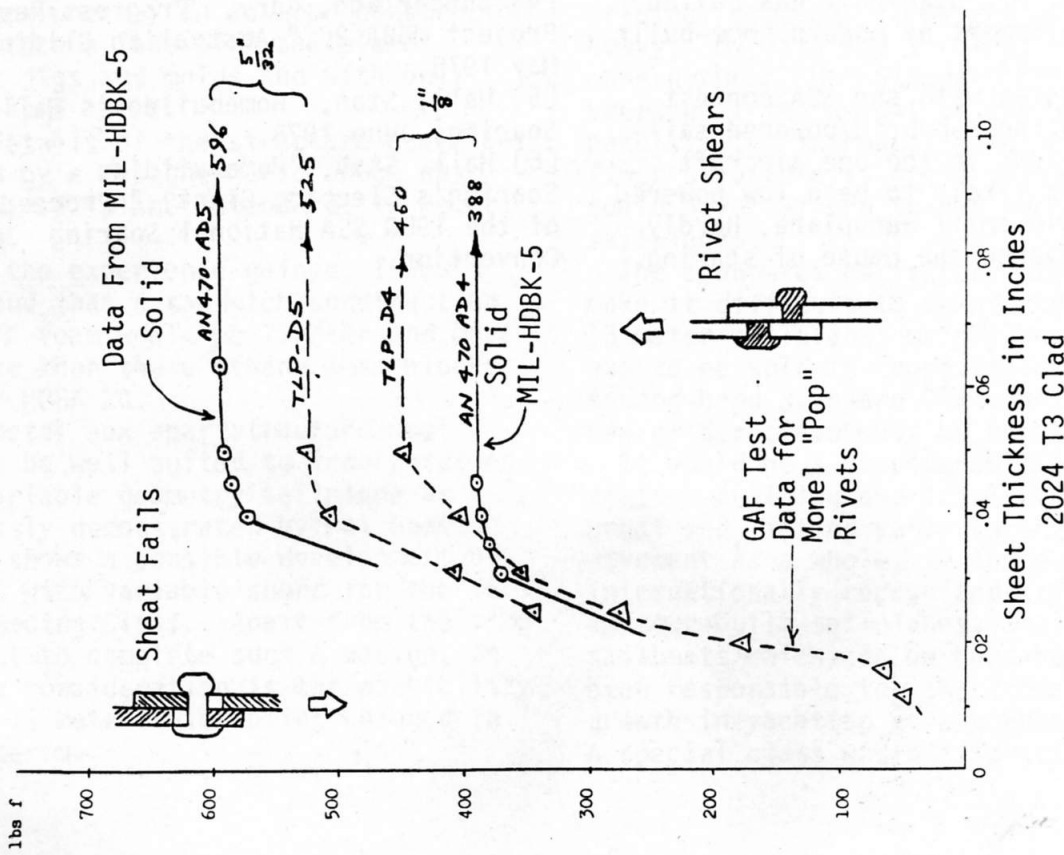

Fig. 1 Ultimate Single Shear Strength for Snap Head Rivets

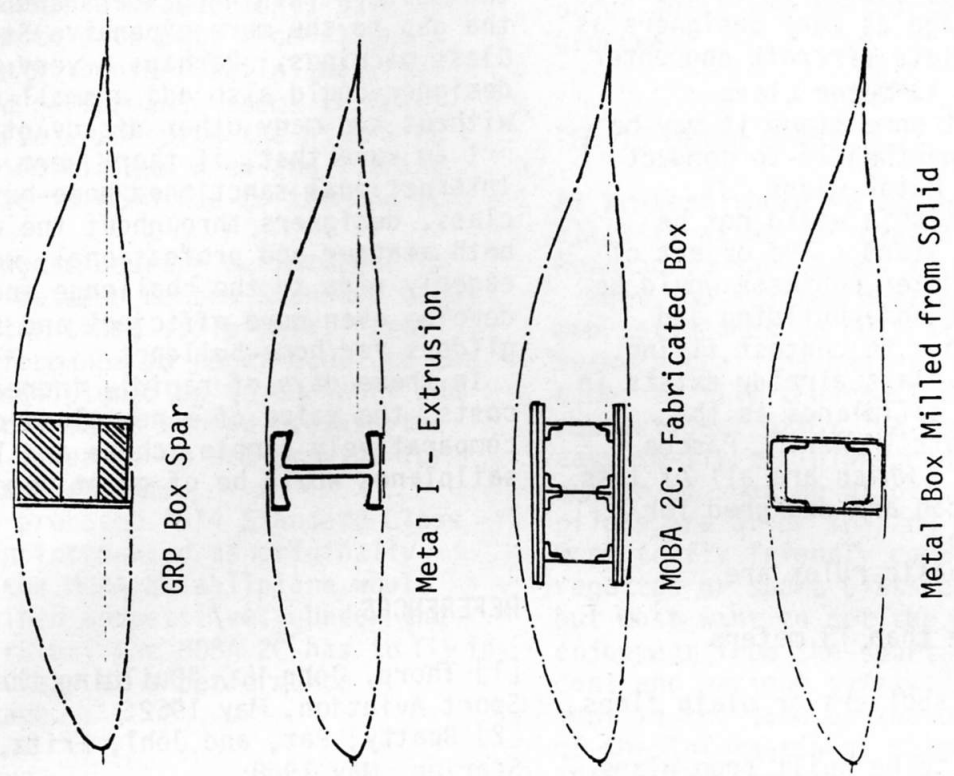

Fig. 2 Typical Spar Boom Locations

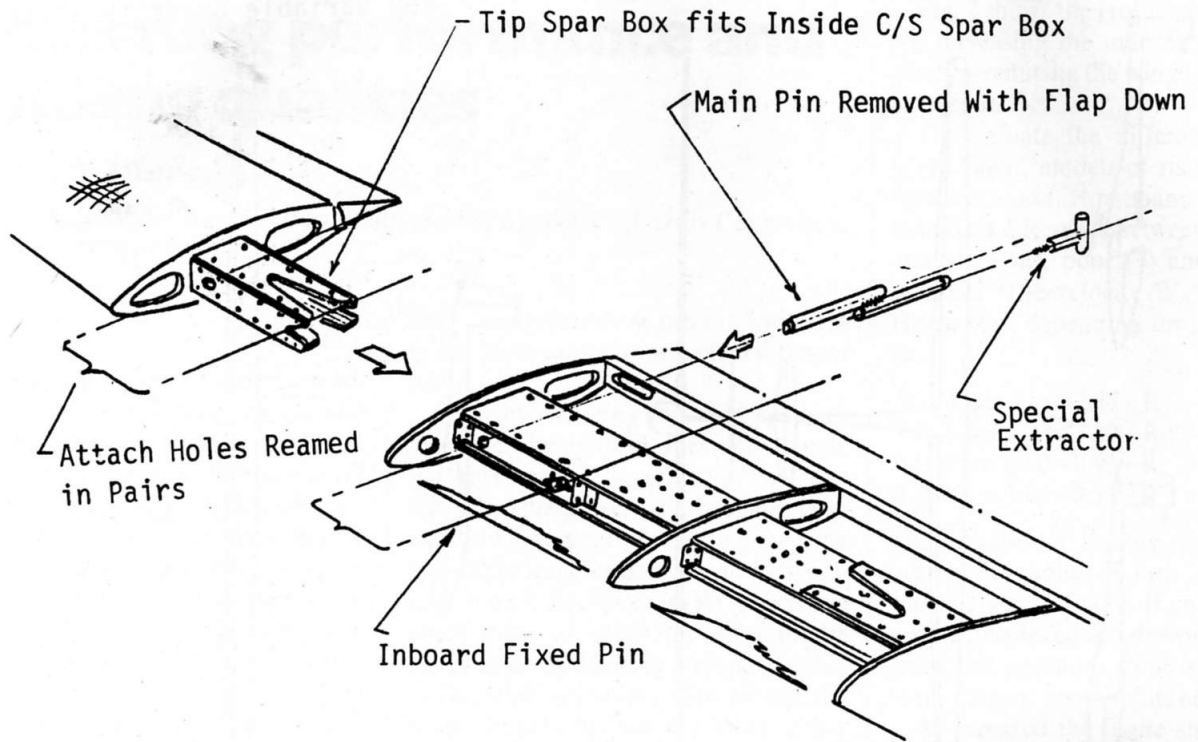

Fig. 3 Wing Tip Attachment

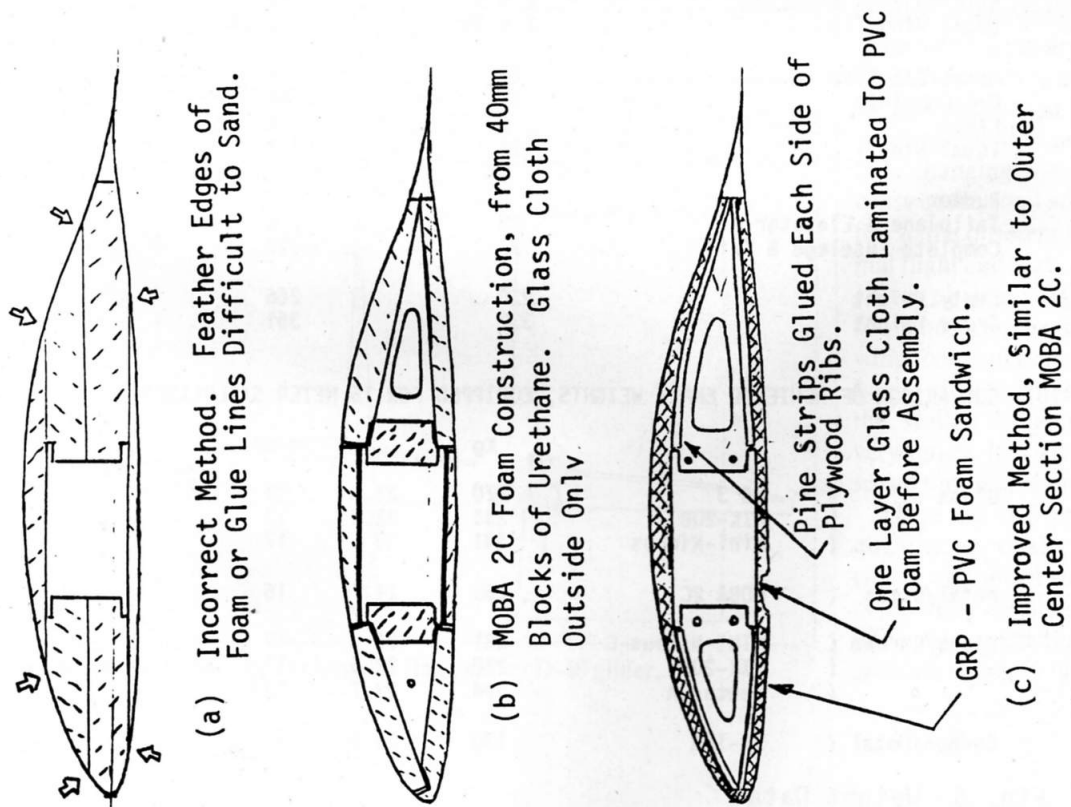

Fig. 4 Foam and Glass Cloth Construction Methods

Fig. 5 MOBA 2C

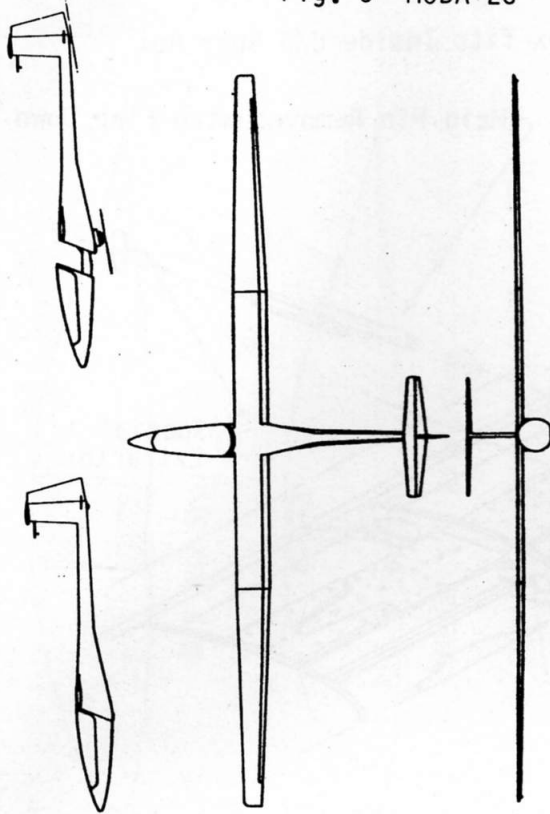
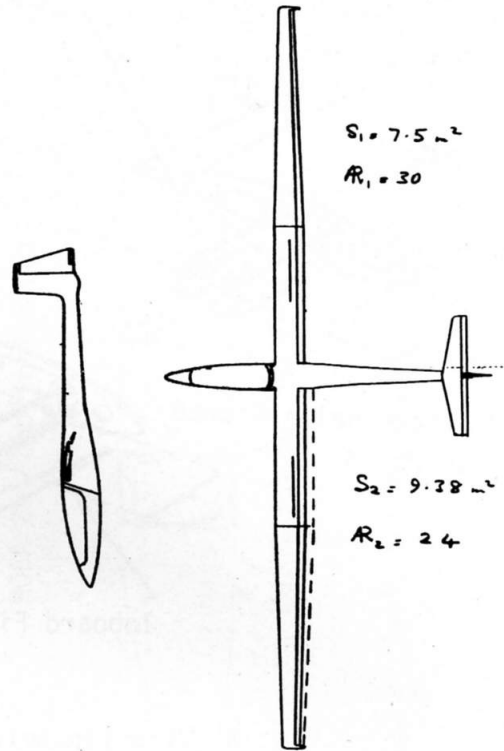

Fig. 7 MOBA 3: "VIRAGO"
15M Variable Geometry Sailplane



(a) MOBA 2C WEIGHT BREAKDOWN

	ESTIMATED Kg	Actual Kg
Metal Tip Spar	2 x 15	2 x 16
Aileron	2 x 3	2 x 3
Total Wing Tip	2 x 28	2 x 34
Metal C/S Spar	44	49
C/S Complete	67	85
Flaps	5	6
Total Wing	124	154
Rudder	2	2
Tailplane & Elevator	5	6
Complete Fuselage & Tail	97	112
Empty Weight	220	266
Gross Weight	332	361

(b) COMPARISON OF ACHIEVED EMPTY WEIGHTS, EQUIPPED FOR 15 METER SAILPLANES

		Kg	t/c%	
Glass	(LS 3	270	21.4	17
	(PIK-20B	235	22.5	17
	(Mini-Nimbus	241	23	17
Metal/Glass	(MOBA 2C	266	24.7	15
Glass/Carbon	(MINI-Nimbus-C	221	23	17
	(PIK-20D	220	22.5	17
	(Ventus-A	224	23.7	13?
Carbon/Metal	(HP-18A	130	21.5	15

Fig. 6 Weight Data