

Fatigue Test of a Sailplane Wing in CFRP Construction

Ch. Kensch
DFVLR WB-BK, Stuttgart

Presented at the XVII OSTIV Congress
Paderborn, Germany
May 1981

Translation by Fred Hermanspann

ABSTRACT

Series production of sailplanes with application of CFRP in primary structures was started some years ago. Taking advantage of the CFRP-inherent capacities required the definition of admissible design data by the glider industry. This paper presents results of investigations on a wing in CFRP-design carried out at the Institut für Bauweisen- und Konstruktionsforschung of the DFVLR in Stuttgart. The aim of the work was to certificate a higher stress level and service life compared to GFRP.

The fatigue tests were run according to a block program commonly used in Germany.

After these dynamic loadings, the wing was tested for residual strength. Periodic measurements allowed observation of stiffness behaviour during the simulated service life.

INTRODUCTION

Today we can look back at 10 years of CFRP (Carbon Fiber Reinforced Plastic) application in the primary structure of sailplanes. Relative to E-glass fibers, high strength (KC 20-) carbon fibers are about one third lighter, but three times as stiff; properties that caught the attention of sailplane producers and Akaflieg groups in Germany when this new material reached the market. Fig. 1 shows clearly the improved specific stiffness and strength values of carbon fibers relative to glass and aramid fibers, as well as traditional materials. While the now well established composite GFRP allowed realistically realizable spans up to 20 m [2], CFRP offered new outstanding possibilities for flight

performance improvements:

- longer spans
- thinner sections
- increase in torsional rigidity
- increase in water ballast (larger range between empty and maximum weight) or lower maximum sink
- easier realization of variable geometry
- reduced flutter problems

For the first Akaflieg prototypes it was only possible to take advantage of the higher stiffness and the lower specific weight. The first certification values for stress levels were only slightly higher than the contemporary GFRP values [2], while those for the service life (3000 hours) were the same, even though the fatigue properties of unidirectional CFRP are better than those of GFRP (Fig. 2).

In 1972, the Akaflieg Braunschweig was able to achieve a span of 29 m on the two-seater SB 10 by using a stiff 8.7 m CFRP center section; in 1975 the Akaflieg Stuttgart flew the telescoping wing FS 29 with a span that could be varied in flight from 13 m to 19 m. The stiffness of CFRP made the required 3 m long hollow shells possible, with a maximum thickness of 3 mm (Fig. 2, ref. 5).

German production sailplanes with CFRP spars flew in 1978 for the first time at the world championship in Chateauroux, together with the SB 11. Sailplane manufacturers delayed large scale application of CFRP because of the high price for the product made from PAN (Poly Acryl Nitrite). With the rapidly increasing demand for carbon fibers, especially by the recreation and aerospace industries, the fiber manufacturers

were able to produce and sell CFRP at lower prices [6].

GOAL DEFINITION

Gradually, consideration was given to certification of higher stress levels in connection with a substantially increased service life, the latter caused partly by reports from Australia [7] and soaring centers in Southern France, locations where sailplanes accrue up to 1000 hours a year.

With collaboration between the LBA (Luftfahrtbundesamt), the BMV (Bundesministerium für Verkehr), the Schempp-Hirth company, the "Institut für Leichtbau und Flugzeugbau" of the TV Braunschweig and members of the ANF (Arbeitskreis Neuartige Faserwerkstoffe), a program was started with the goal of qualifying new certification levels with fatigue tests of CFRP structures, according to Franzmeyer [8]. Fig. 4 shows the desired goals for CFRP relative to GFRP.

TEST ARTICLES

The Nimbus 2 was chosen as a suitable test object for CFRP structures; its construction had been proven in several hundred GFRP and a few CFRP examples. The four-part, 20.3 m wing allowed a "familiarization test" on the smaller outer wing. It was tested at slightly lower stress levels than given in Fig. 4; tests were performed at the TV Braunschweig [9].

The design for the test wing was based on the results from preceding evaluations of GFRP spars, conducted at the DVL Stuttgart [10]. The design was for a plane equal in maximum weight to the production version, to ensure equal outer loads. To achieve the desired high spar cap stress levels in the test wing, less structural carbon fiber material was used. The structural composition of the inner wing, which is the subject of this report, is given in Fig. 6. The torsion shell uses a $\pm 45^\circ$ CFRP/Conticell/ $\pm 45^\circ$ GFRP sandwich construction. The box spar gets its bending stiffness from CFRP caps, while GFRP was sufficient for laminating the Conticell cores of the webs. The CFRP composites of the skin use high strength carbon fiber. The CIBA resin XB 2878 was employed as a laminating

resin (cold curing 24 hours, tempering at 50°C for 15 hours).

TEST SET-UP

Fig. 7 shows a sketch of the test set-up. Loading for static tests, as well as the fatigue test, was applied with the servo-hydraulic rig at the institute. The loading frames and jigs were manufactured especially for the test. It was also necessary to build a specially reinforced outer wing "dummy" which simulated the total lift of the outer wing as a point load applied at the end. Thus, it was always possible to test the outer wing attachment. The fuselage attachment points were loaded according to actual flight conditions with a levered rig. The wing was supported at the main bolt near the wing root. For negative load cases, weights were attached to the load beams. A conventional application of the loads on the wing, with a cylinder acting on the load harness, was not advisable as this would not allow the desired test frequency with the required large tip weight and large tip deflections (compare Fig. 14 for wing bending). Therefore, the attach point for the hydraulic cylinder was moved to the extended spar stub and the load harness was fixed at one point. This had the advantage of keeping the movement of the outer load beam quite small.

The position of the load beams followed from the theoretical normal force distribution plotted in Fig. 8. Also shown are the step-wise increase in normal force resulting from the load application through the load beams and the bending moment distribution. The corresponding bending line has the same shape as with conventional loading. According to ref. 11, the calculated maximum loads resulted from normal accelerations of $n = +5.9$ or $n = -3.9$, assuming a gust of ± 10 m/s at v_D .

For static tests, the measured values consisted of the strain rates of the strain gauges bonded to the wing (Fig. 7), the forces of the load cells attached to the cylinder and to the attach point of the load harness, as well as the movements of the four load beams and cylinder piston beam. The block diagram for the data acquisition and reduction is shown in

Fig. 9. In general, the load was applied continually within one minute. Because of the fast sampling rate of .2 ms/measurement point, proper correlation of deformation and force was still possible. Data recording generally took place every 2 s.

The load cycle program was force controlled by the computer [12]. The maximum stress level of the cylinder load cell was recorded to determine the time of a potential failure of the test apparatus during its automatic operation. A cut-off of the test was provided by deformation dependent limits in the electro-hydraulic control system in case the cylinder stroke became disproportional to the force due to a change in wing stiffness or some other reason.

According to the LBA guidelines described in ref. 13, ultimate load tests on sailplane structures have to take place at 54°C. For this purpose a temporary heat chamber was built around the whole test set-up.

FATIGUE TEST

There are currently no analytical methods that are applicable for the service life prediction of composite structures. While application tests are conducted on the basis of the linear or relative Miner rule, the results do not constitute a reliable base for the certification of a given service life, especially as the results come out totally different as a function of composite build-up. Therefore, operational fatigue tests for primary CFRP structures are mandatory.

At the TV Braunschweig, numerous service life evaluations of GFRP sailplanes were conducted from 1962 to 1969. Block diagrams were developed which reflect the assumed load history of sailplanes as fatigue programs.

This development culminated in the so-called "Franzmeyer" block program [8]. In the last 13 years this has become the standard program for all evaluations of primary GFRP structures in Germany and likewise for the CFRP spars and wing discussed here. It is based on statistically determined random loads, which depend on conditions like assumed flight

maneuvers. These load variations in flight were assigned to blocks of equal base loads and different cyclic loads.

This program accounts for gust load cycles during winch tow as well as in aero-towing, thermalling, cross-country and high-speed flying, and includes take-off, landing and rolling load cycles (Fig. 10).

The number of load cycles follows from the assumption of an allowable service life of 3000 flight hours and a certain number of load cycles per flight hour. As the service life prediction still does not appear reliable enough after such a test, a life-span factor of 3 was and is applied to the service life tests. That meant that 9000 hours had to be demonstrated in the tests; in our case, 18,000, to achieve the desired certification of 6000 flight hours.

The discrete blocks were sequenced with decreasing amplitudes. In investigations by Schijve [14] it had been proven on samples of aluminum alloys that blocks starting with high amplitudes and showing then a falling tendency, as well as those with increasing and then decreasing amplitudes, achieved a shorter life span than those that start small and increase in steps. Because of lack of experience in the behaviour of composite structures, similar characteristics were assumed and applied to the service life investigation of sailplane structures in CFRP and GFRP.

However, in order to simplify the practical application of the program, it was again taken apart and rearranged with a 24 hour cyclus in a sequence of 88 days ($\hat{=}$ 18,000 flight hours). See Fig. 11. This made possible a very simple computer program to control the test while the cyclicly repeated load sequences correspond better to the actual load history of the sailplane than the original program.

TEST HISTORY

The fatigue test, including all static load evaluations, took place from July 17, 1979 to July 16, 1980. The basis for the investigations were the LBA guidelines given in ref. 13 and the

above described block diagram.

The conducted tests are listed in Fig. 12 in comparison with the CFRP spar investigations from ref. 10 and the evaluation of the outer wing at the TV Braunschweig. The wing was stressed before the fatigue test at room temperatures (RT) up to the safe load. The measured maximum strain level amounted to about 0.4%. This appeared to be too high as the safety factor of 1.5 required for the proof of the calculated ultimate load strength could have resulted in a stress level too close to the strength limit of the material. To avoid this risk, the safe load was reduced by 7% such that the new reference strain limit still yielded a safe strength of over 400 N/mm².

Before starting the fatigue test program, test cycles for all 18 load steps of the program were required to establish the frequencies at which these program steps could be optimally operated.

To gain insight into the effect of the load cycle stresses on the stiffness behaviour of the CFRP structure, static check tests were conducted every 5 test days up to a load of $j = 0.5$. These included measurements of strain, deformation, and force, according to Fig. 9. After positive comparisons with previous measurements, the fatigue test was continued.

At the conclusion of this program, another static test was made at RT up to $j = 1.0$.

To achieve the LBA certification of the desired values, a static test at 54°C was necessary at a load level up to $j = 1.5$, which had to be sustained for at least 3 seconds without causing damage or permanent deformations on the wing.

An ultimate load test of the residual strength, also at 54°C, concluded these long and involved evaluations.

RESULTS

The highest strain level along the spar cap was measured 1 m away from the wing root at strain gauge DMS 39 (Fig. 7,13). At a load corresponding to $j = 1.0$, it amounted to 0.37%. Based on the average E-modulus of 115 000 N/mm², measured on

sections of the outer wing, this results in a calculated compression stress level in the upper spar cap of 426.3 N/mm². This was chosen as the reference stress level for the fatigue test and thus for proof of the service life of 6000 hours. The deflections measured during the static tests at the load points are depicted in Fig. 14. They are referenced to a line through cylinder attach and main bolt rotation points.

The results derived from the static control tests conducted during the fatigue tests are documented in Fig. 15, which shows the nondimensional E-modulus (E_0 = reference E-modulus) for location at DMS 39 where 100% service life in this diagram corresponds to $1.2 \cdot 10^7$ load cycles. The stiffness variations are very small and not serious. Comparing the measured deflections before and after the dynamic load test at $j = 1.0$, one can conclude, on the basis of the data agreement, that the wing didn't suffer from the fatigue test. It may be of interest in this context though that the normal force fittings and the steel pins used for the moment application at the spar stub ends showed strong gouging, even though this didn't affect the test results.

The tests for the proof of the calculated ultimate load factor and the residual strength took place in a heat chamber at elevated temperature. The wing was heated for this purpose for 5 hours in each case to achieve an even temperature distribution throughout the wing. One hour before the test the temperatures measured on the surface were already about 54°C.

With the test at $j = 1.5$, the LBA conditions defined in ref. 13 were met. In the concluding ultimate load test the residual strength of the CFRP spars could unfortunately not clearly be established as a normal force fitting in the connecting tunnel between inner and outer wing panels was ripped out of the CFRP composite, and the CFRP stub of the outer wing broke at the location of the normal force pin because of excessive normal force (Fig. 16).

The strain-derived spar cap stress levels were plotted in Fig. 17 together with the GFRP strength values calculated according to VDI 2013 [15] for safe load

($j = 1.0$), calculated ultimate load ($j = 1.5$) and achieved ultimate load ($j = 1.84$). The "failure" stress amounted to 784 N/mm^2 , while the spar web strength value K_{Gdf} reached 23.2 km .

As the fiber content of spar samples of the outer wing was known (56.6%) and applicable to the inner wing, it was possible to establish the K_{Gdf} values for the compression spar cap. They are given in Fig. 18, along with the strength values for the GFRP web. The maximum value amounts to about 80.5 km .

SUMMARY AND OUTLOOK

At the Institut WB-BK of the DFVLR Stuttgart, a fatigue test of an inner wing in CFRP construction of the Nimbus 2 sailplane was conducted. The objective was to investigate the fatigue behaviour of a highly stressed CFRP structure and to quantify new structural allowables for spar cap stress levels together with the web loading, while at the same time increasing the service life from 3000 hours to 6000 hours.

- No stiffness changes were observed during the tests.

It was demonstrated that it is possible to;

- increase the compression stress level in a CFRP spar cap to more than 400 N/mm^2
- certify at the same time an increase of the allowable service life to 6000 flight hours

As the inner wing was not destroyed in its basic structure and required little effort to repair the damages, it is available for further studies. For the future, a 10 year program of natural weather exposure is planned.

Influences such as humidity, temperature cycles and UV radiation will be evaluated in further tests. If we need to do tests to further extend the service life, this wing will be suitable because of its aging history.

The presently used load block diagram for service life certification could be replaced in the future by a random procedure based on data from load-time histories measured in-flight on the wing spar and fuselage shell of a Janus. A computer program has been developed in

cooperation with the DFVLR and the TV Braunschweig; this should result in more realistic service loads for the tested structures.

REFERENCES

- [1] Niederstadt, G., "Kriterien und Beispiele für die Wahl von Verbundwerkstoffen mit Fasern hoher spezifischer Eigenschaften," in: "Kohlenstoff- und aramidfaser-verstärkte Kunststoffe," VDI-Verlag, Düsseldorf, 1977.
- [2] Thielemann, F.W., "Experience with Composites as obtained from Gliders," AGARD-Symposium, Toulouse, Sept. 1972, Conference Proceeding #112.
- [3] Stender, W., "Praxisnahe Abschätzungs- und Vorbeugungsmöglichkeiten gegen die Flattergefährdung von Segelflugzeugen und kleinen Motorflugzeugen," DFVLR, Institut für Aerodynamik, Braunschweig, 1974.
- [4] Grüniger, G., Kochendorfer, P., "Fiber Reinforced Materials for Application in the Cold Parts of Turbine Engines," AGARD-Symposium, Toulouse, Sept., 1972, Conference Proceeding #112.
- [5] 1926-1976, 50 Jahre Akaflieg Stuttgart.
- [6] Rose, P.G., "Hochfeste C-Fasern auf PAN-Basis VDI-Tagung Kunststofftechnik," Baden-Baden, 1981.
- [7] Esson, G.P., Patching, C.A., "Fatigue Life Considerations for Gliders operated in Australia", Aero-Rev., 10/79 and OSTIV-Publ. XV, 1978
- [8] Franzmeyer, F.K., "Wissenschaftliche Untersuchungen über die Anwendung von glasfaserverstärkten Kunststoffen in hochbeanspruchten Leichtbauteilen," Teil VIII: "Statische und dynamische Festigkeitsuntersuchungen an einer Tragfläche des Segelflugzeuges Cirrus," Bericht 69-02 des Instituts für Flugzeugbau und Leichtbau der TH Braunschweig, 1969.
- [9] Tunker, H., Betriebsbelastungsversuch am CFK-Augenflügel des Nimbus 2 Vortrag "Segelflugsymposium" in Braunschweig, 1979.
- [10] Hinz, B., "Statische und dynamische Biegeversuche an CFK-Holmen mit kastenförmigem Querschnitt," DFVLR, Interner Bericht 454, 78-2, 1978.
- [11] LBA, LFS (66).
- [12] Storm, O., "Beschreibung eines Computerprogrammes für Ermüdungsversuch an Segelflugzeugflügeln nach Franzmeyer," DFVLR, IB, 1979.
- [13] LBA, "Vorläufige Richtlinien zur

Führung des Festigkeitsnachweises für Bauteile aus kohlenstoffaserverstärkten Kunststoffen von Segelfulgzeugen und Motorseglern," Mai 1980.
 [14] Schijve, J., "The Endurance under Program Fatigue Testing," Plantema,

F.J. and Schijve, J., "Full Scale Fatigue Testing of Aircraft Structures," Oxford, London, New York, Paris, Pergamon Press, 1961.
 [15] Dimensionieren von Bauteilen aus GFK VDI 2013, 1/1970.

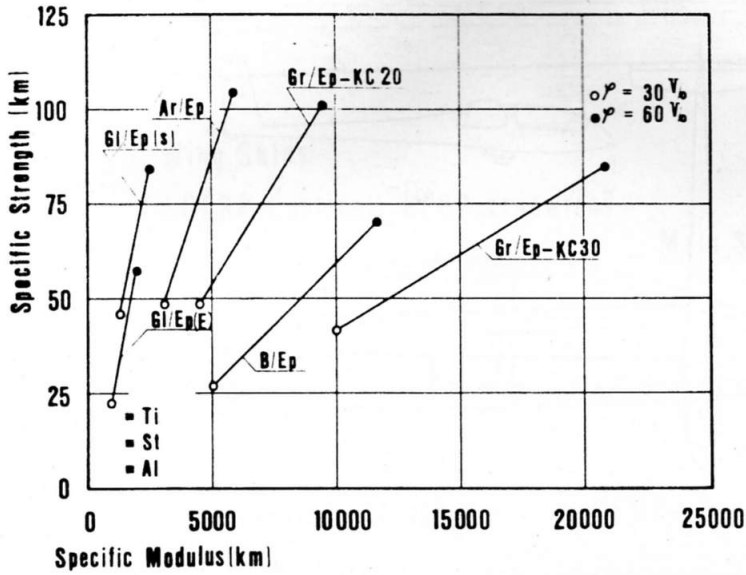

Fig.1 Specific Strength vs. Specific Modulus UD-Composites, Ref. [1]

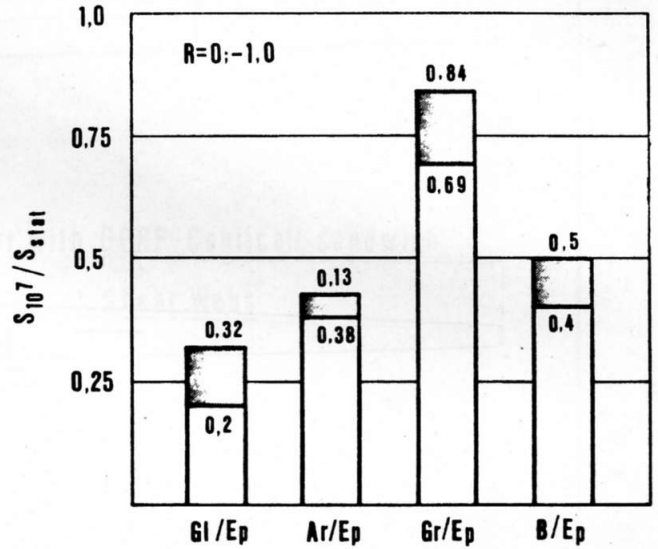

Fig.2 Fatigue limits of UD composites [4]

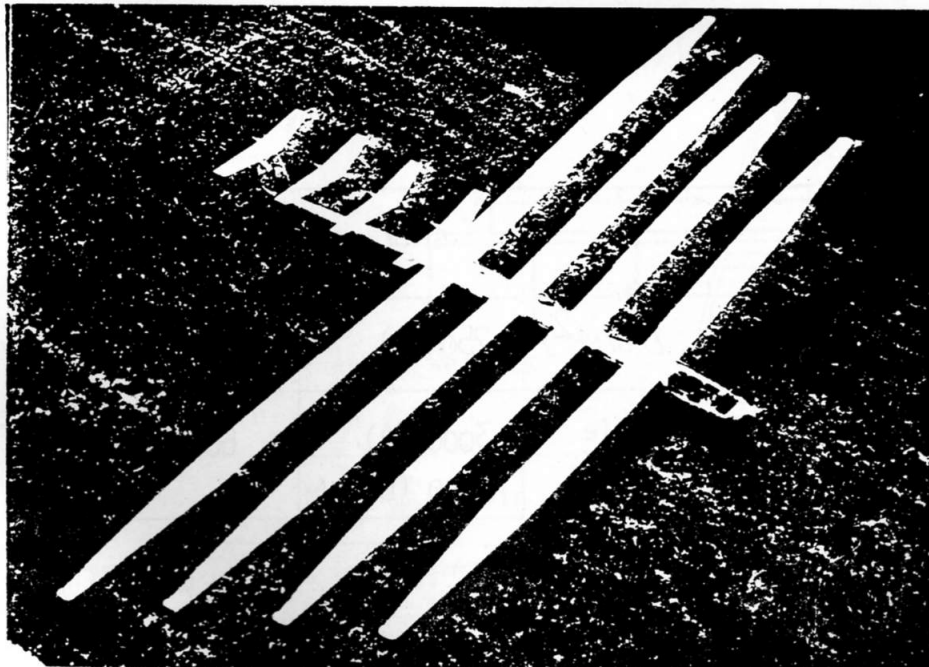

FIG.3 Telescoping CFRP Sailplane FS 29

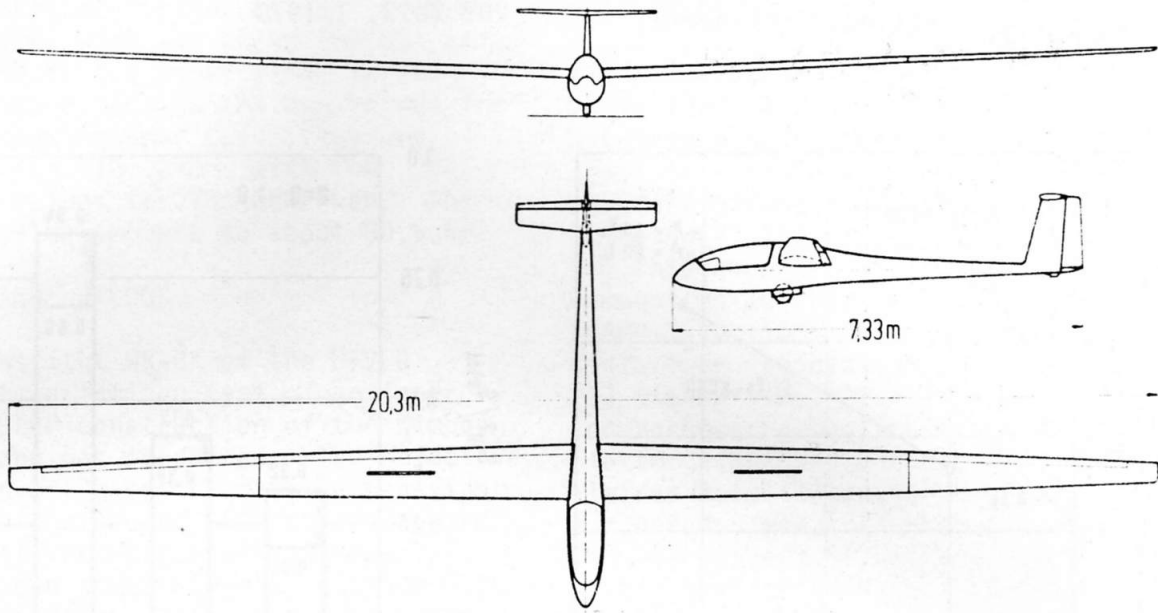
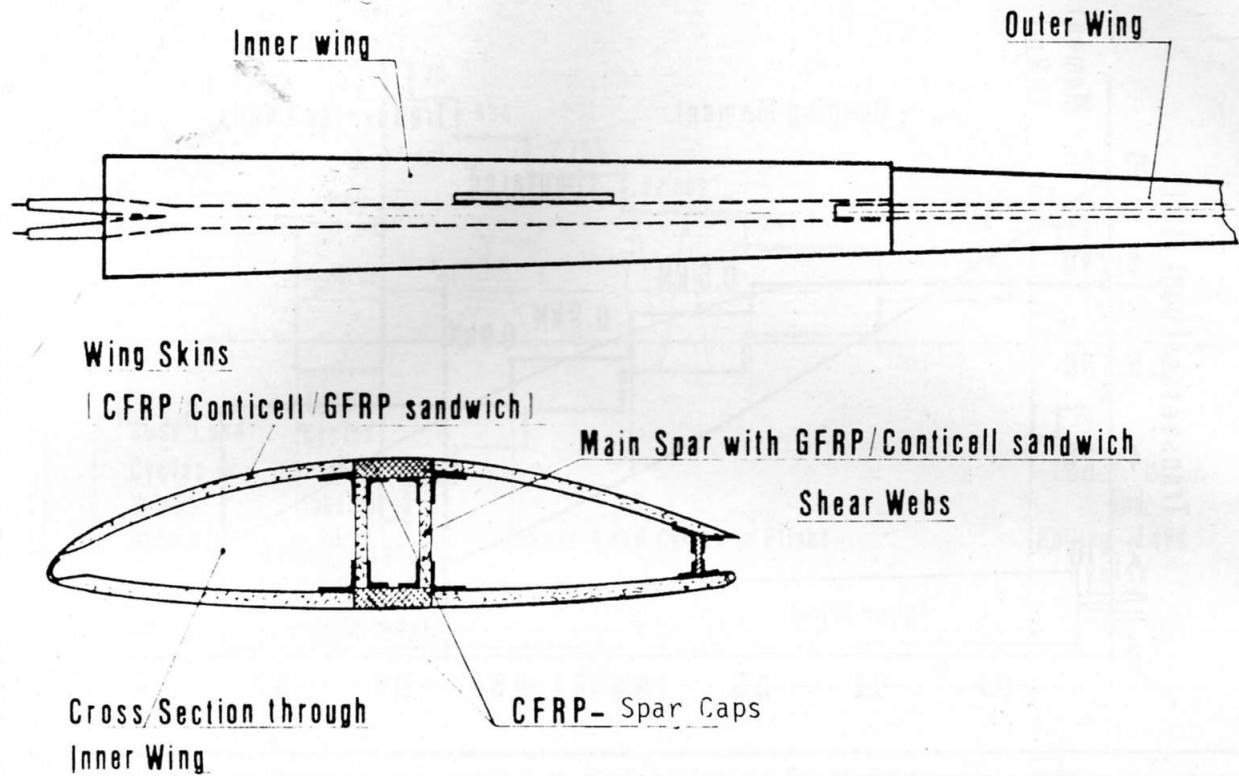

Fig. 5 High Performance Sailplane Nimbus 2

	GFRP	CFRP
$\sigma_{J=1,0} [N/mm^2]$	250 (A)	400 (B)
Service Life Flight Hours	3000 (A) 6000 (B)	6000 (B)

A: Current
B: Desired

FIG. 4: Certification Standards for Sailplanes



General View of Structure of Wing 7

Fig. 6

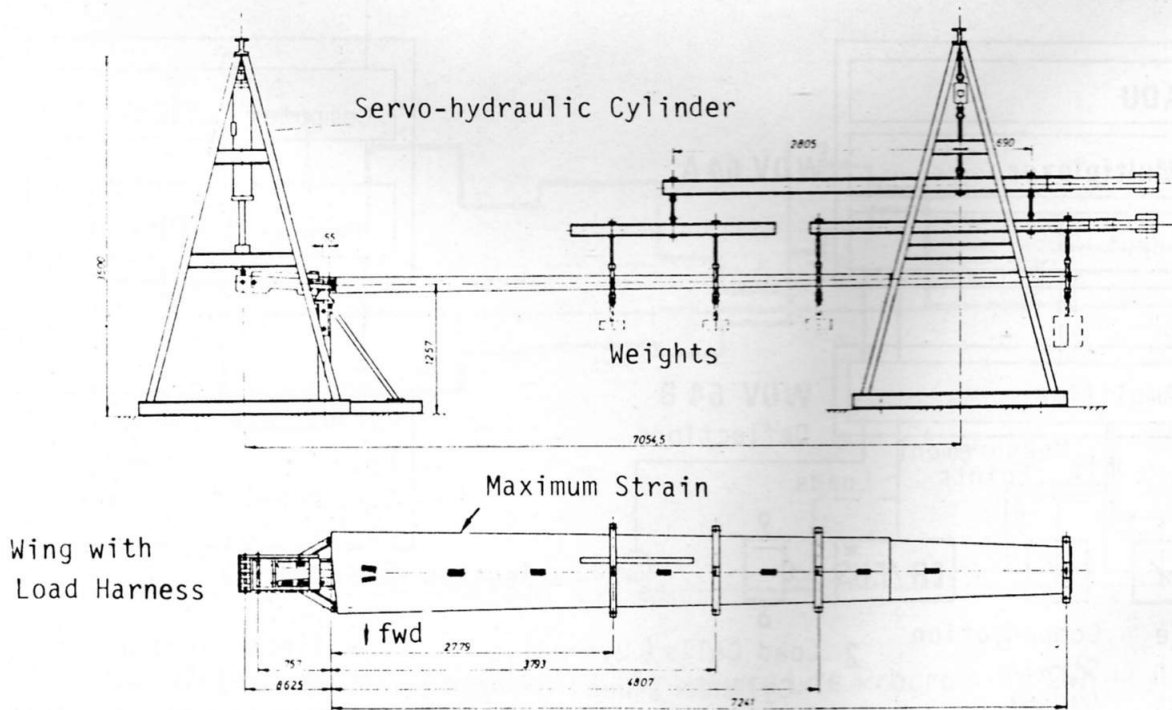

Test Set-up of the CFRP Wing

Fig. 7

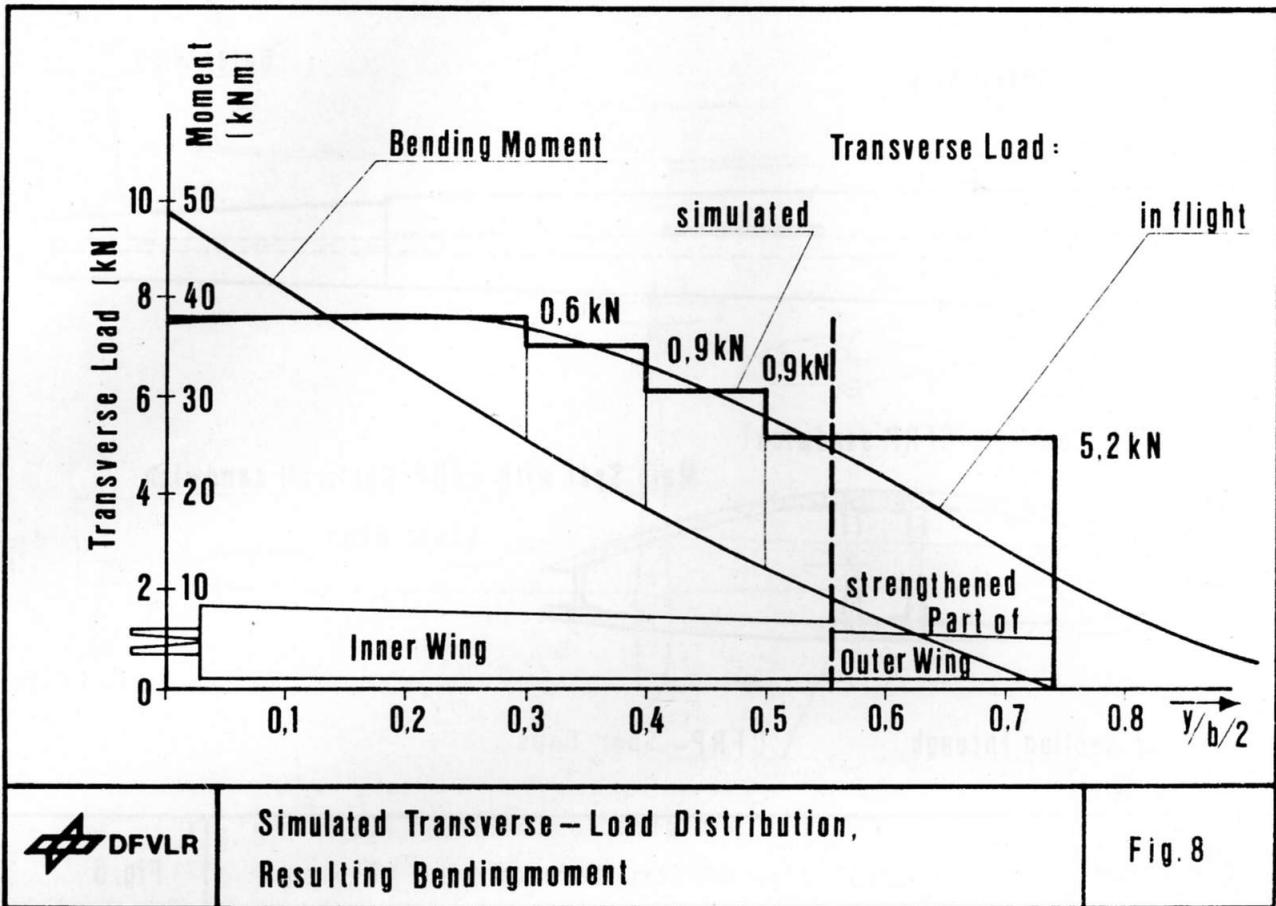

Simulated Transverse—Load Distribution, Resulting Bendingmoment

Fig. 8

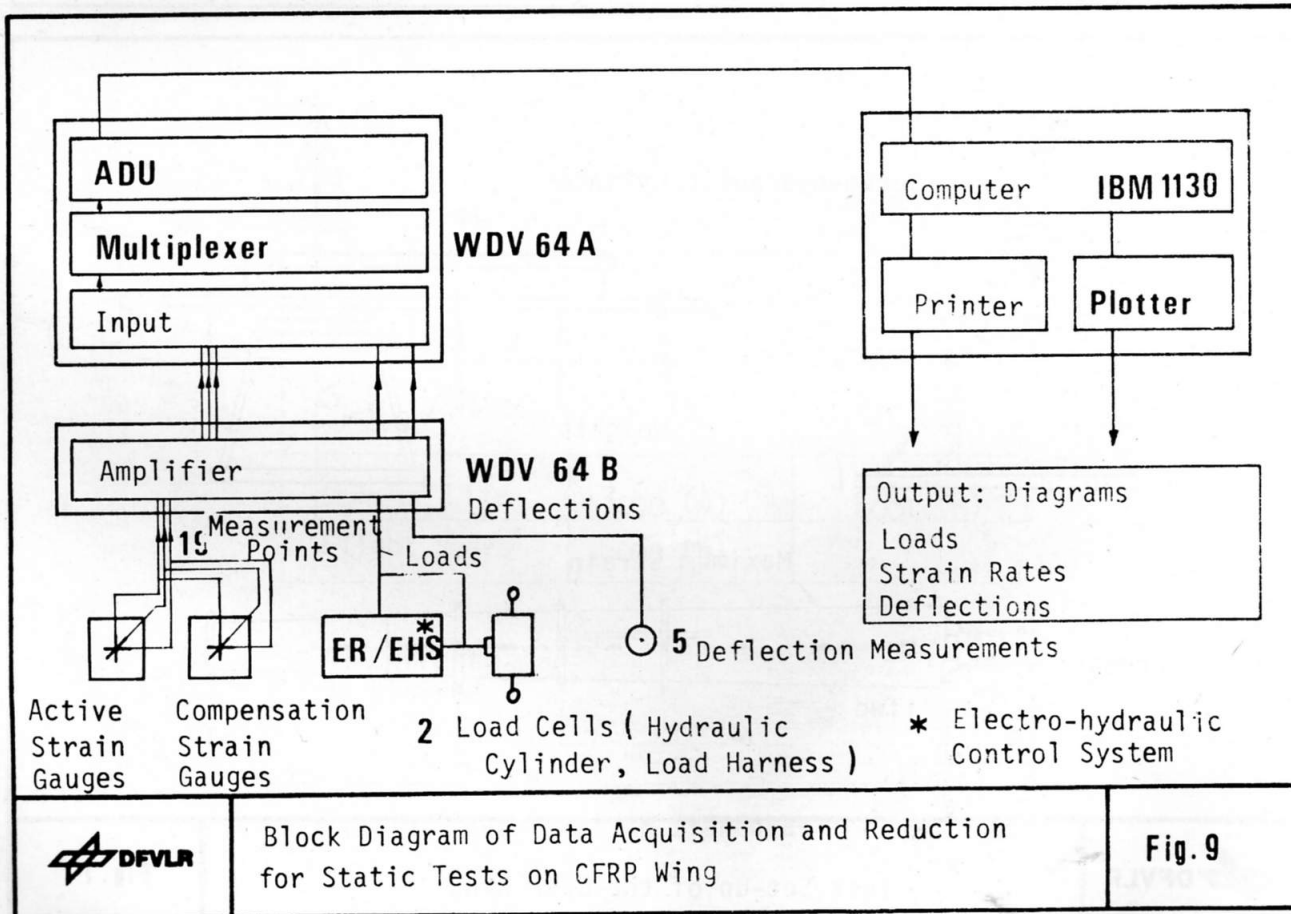

Block Diagram of Data Acquisition and Reduction for Static Tests on CFRP Wing

Fig. 9

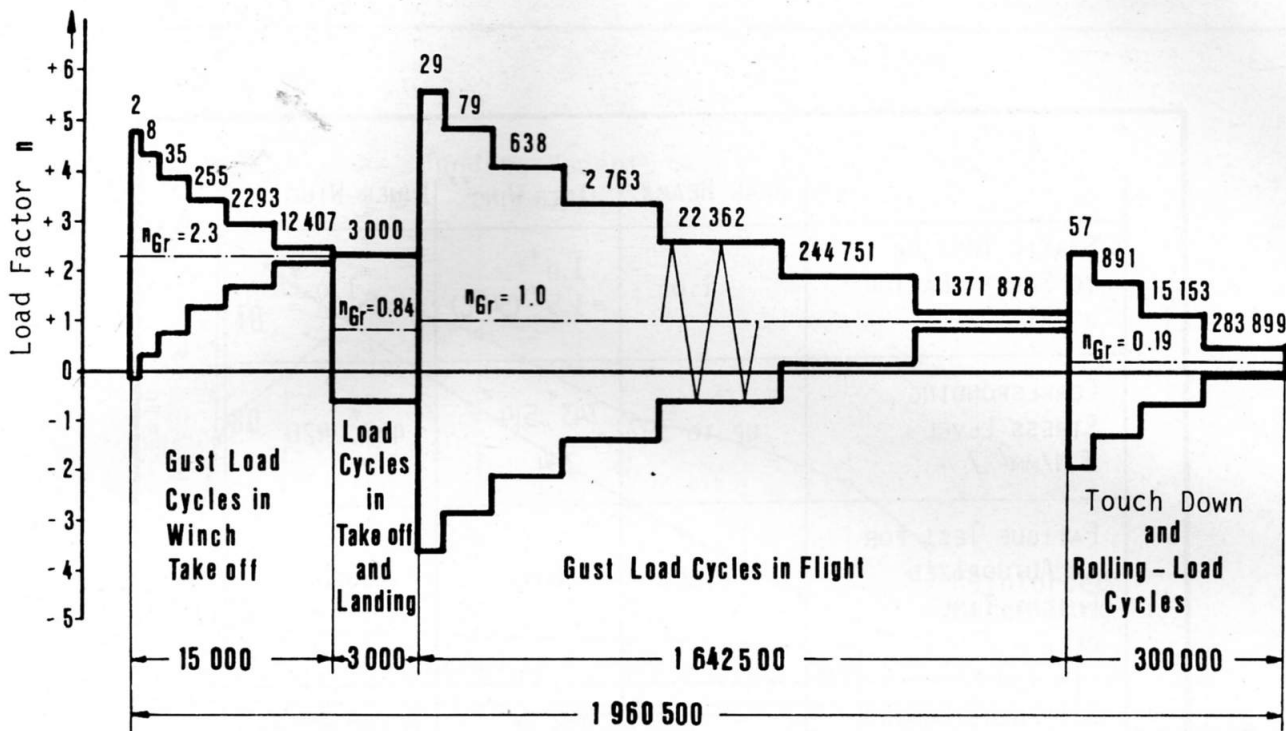

Fig.10 Service Life Program corresponding to 1000 Authorized Flight Hours

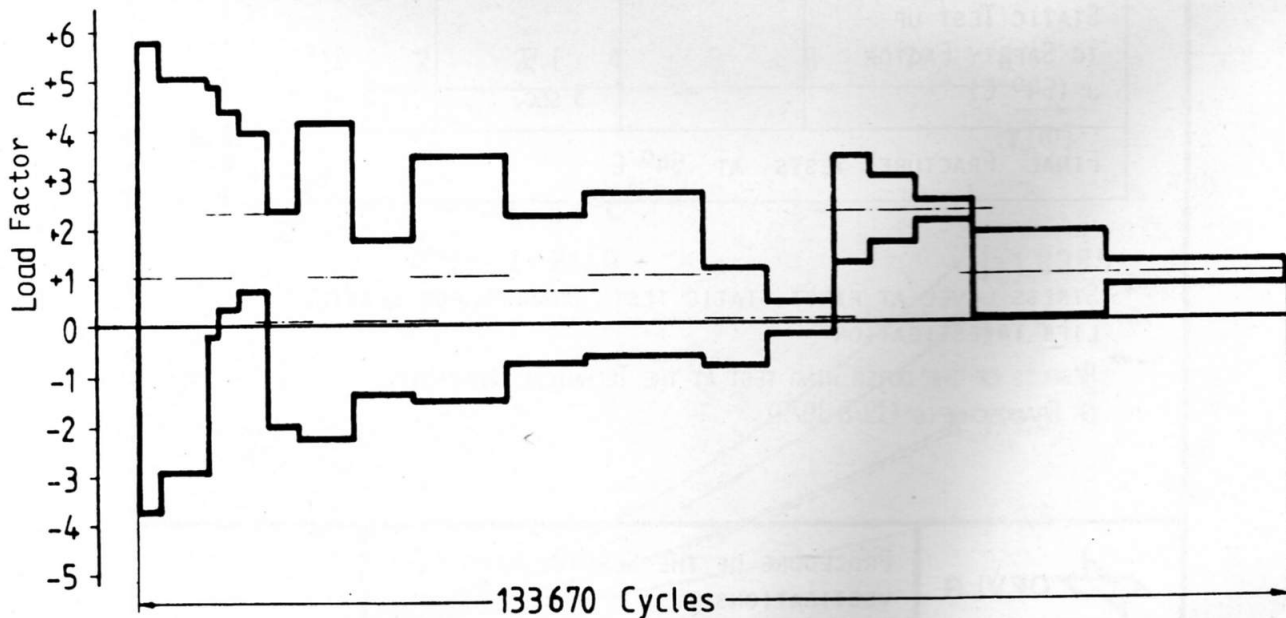

Fig.11 Splitting and Rearrangement of the Service Life Program for 24h - Cycle

	SPAR BEAMS	OUTER WING**	INNER WING
STATIC TEST UP TO SAFETY FACTOR J (RT)	1.0	1.0* 1.5* (54°C)	1.0*
CORRESPONDING STRESS LEVEL [N/MM ²]	UP TO 392	343*, 514* 394	463*, 426
FATIGUE TEST FOR AN AUTHORIZED FLIGHT TIME OF [H]	3000	6000	6000
STIFFNESS-CONTROL TEST DURING FATIGUE-TEST	--	TEST BY FREE OSCILLATION	MEASUREMENT OF STRAIN AT J = 0,5
FINAL STATIC TEST UP TO SAFETY FACTOR J (RT)	1.0		
STATIC TEST UP TO SAFETY FACTOR J (54° C)	--	1.5 3 SEC.	1.5 3 SEC.
FINAL FRACTURE TESTS AT 54° C			

* STRESS LEVEL AT FIRST STATIC TEST, CHANGED FOR SERVICE LIFE INVESTIGATION

** RESULTS OF THE OUTER WING TEST AT THE TECHNICAL UNIVERSITY OF BRAUNSCHWEIG (1978-1979)



PROCEDURE OF THE SERVICE LIFE INVESTIGATIONS

FIG. 12

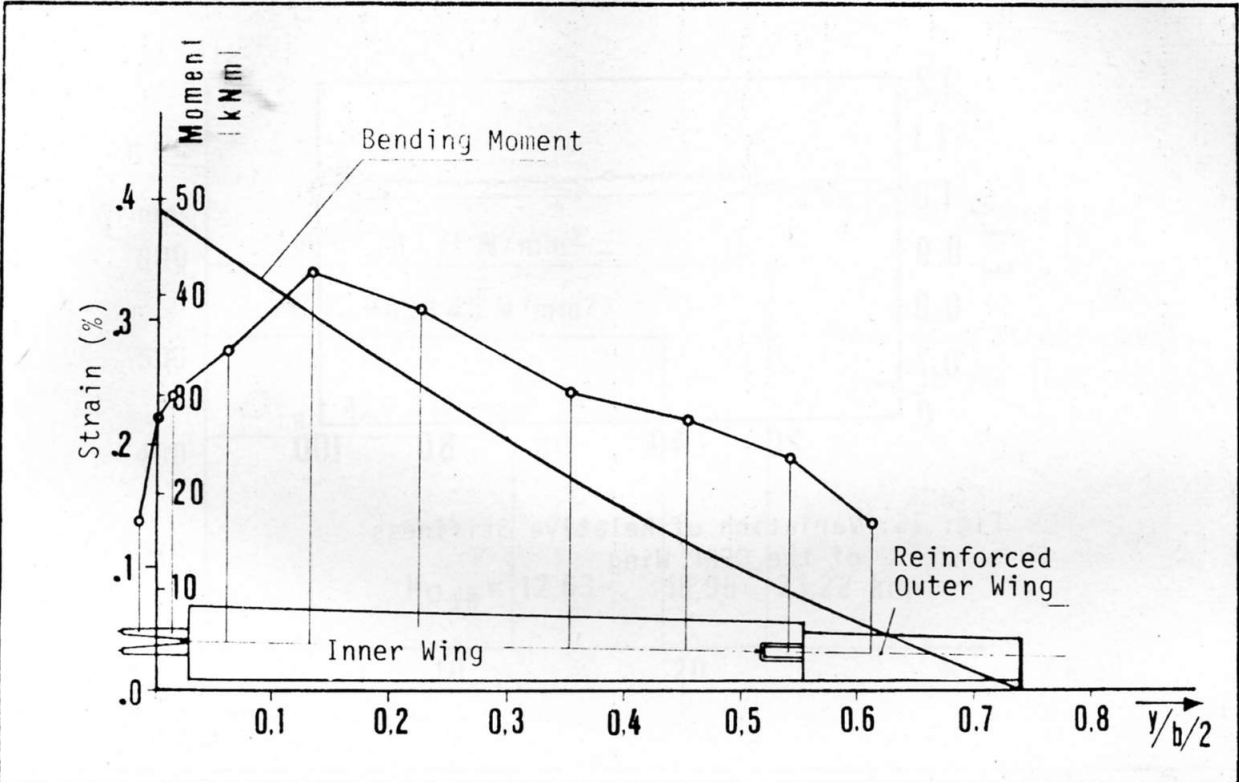

DFVLR Strain Distribution in Upper Spar Cap for Bending Moment Corresponding to Design Load **Fig. 13**

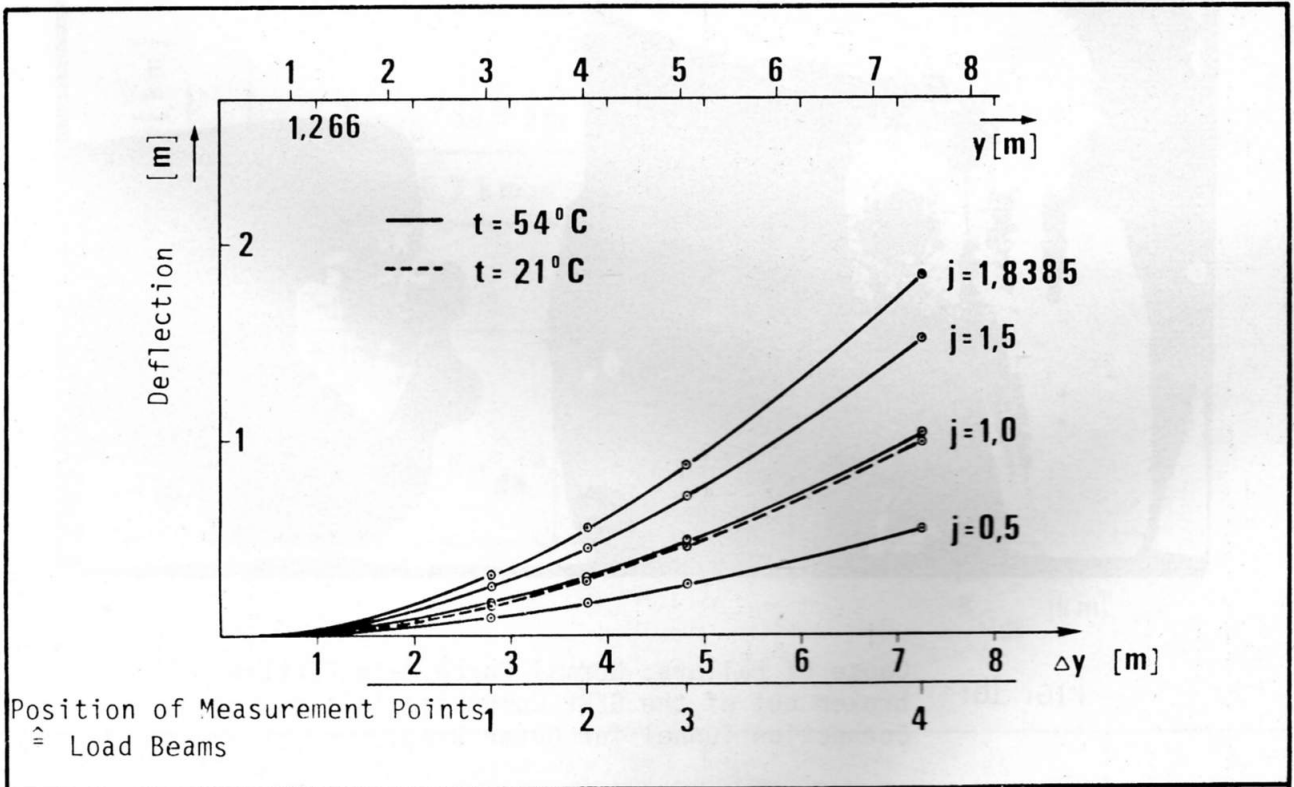

DFVLR Bending Line of CFRP Wing for $j = 0.5, 1.0, 1.5, \text{ and } 1.8385$ (Failure) **Fig. 14**

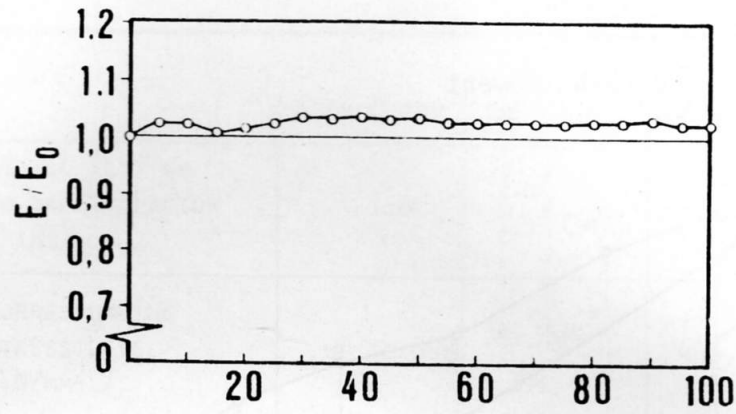

Fig. 15: Variation of Relative Stiffness of the CFRP Wing

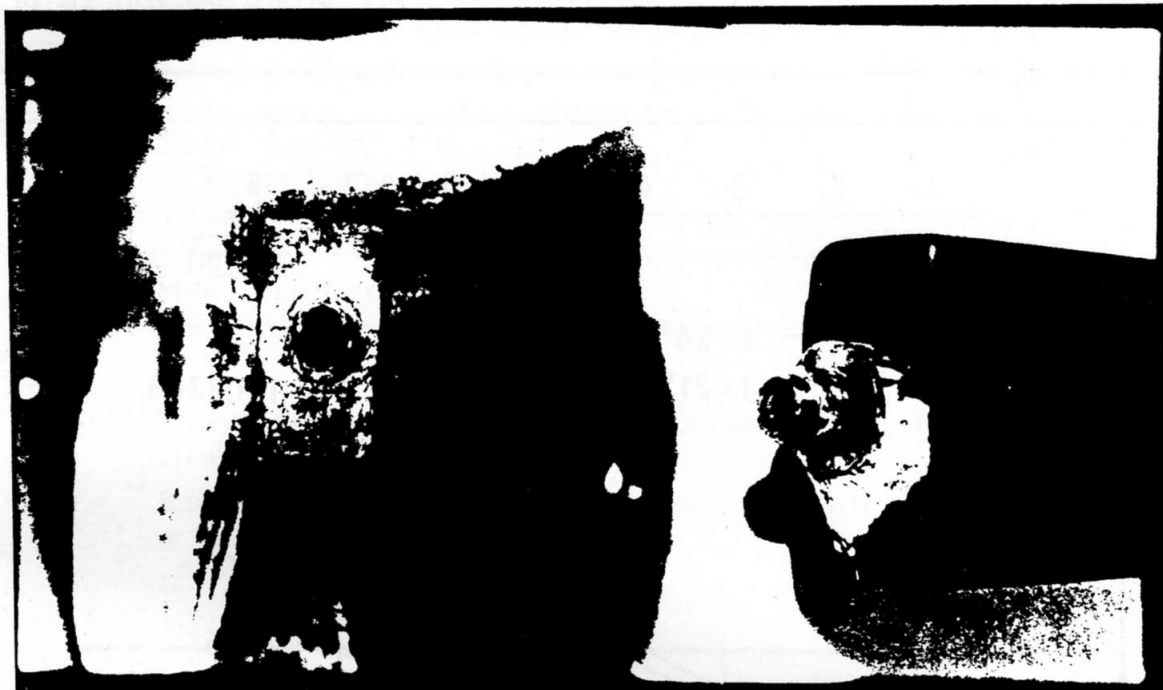
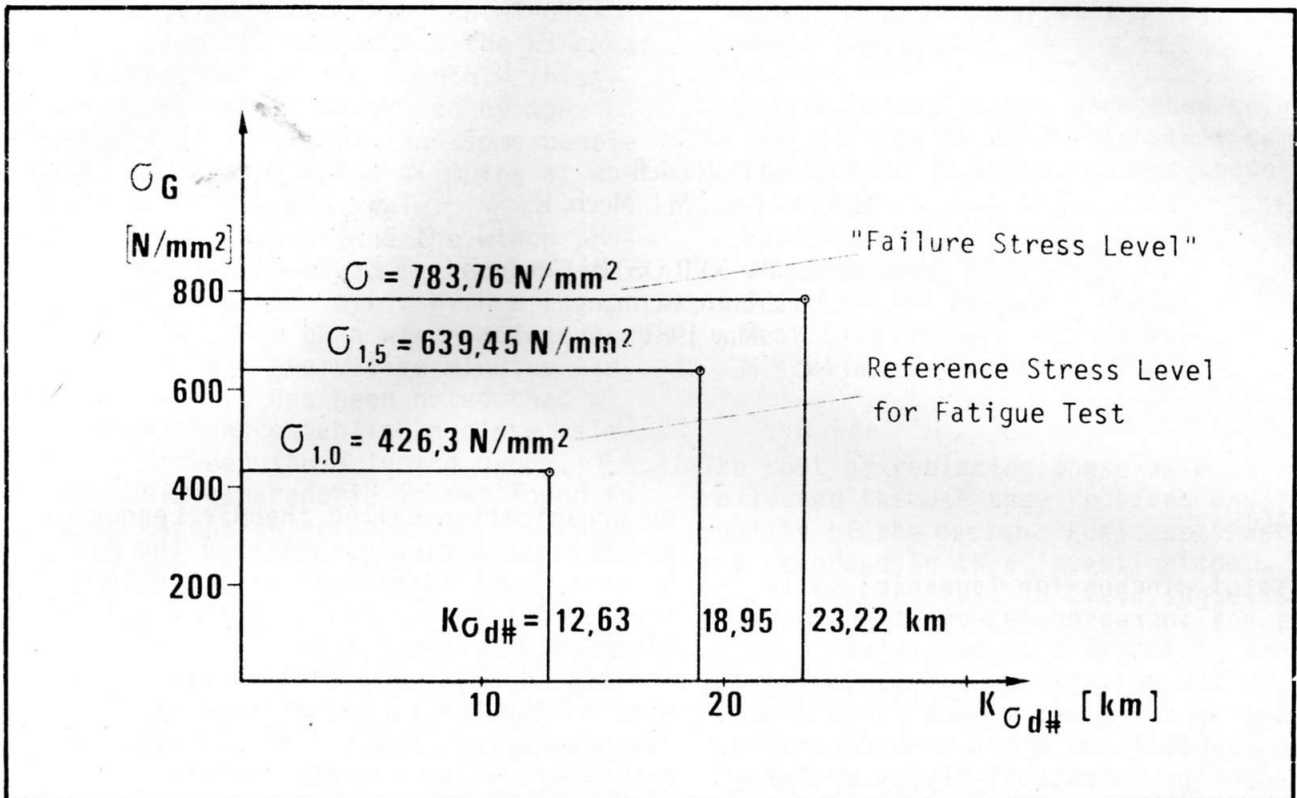

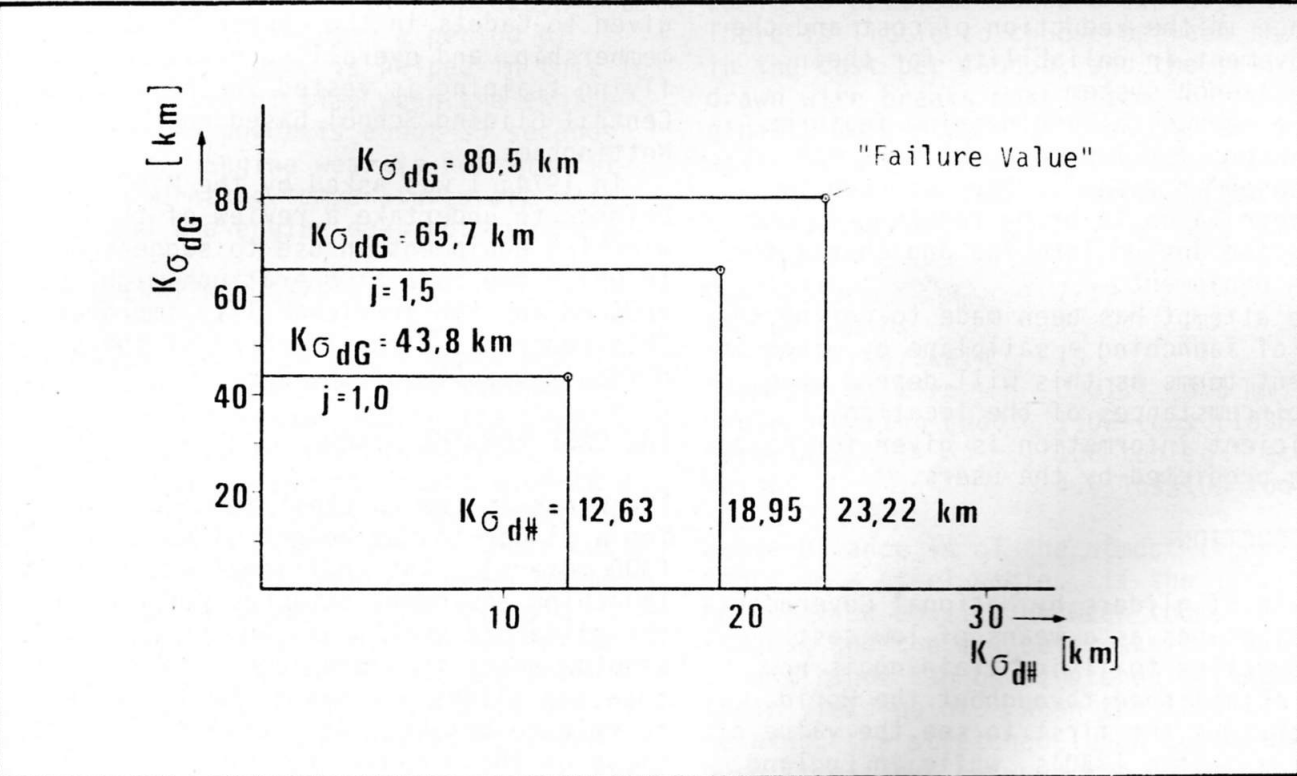



FIG. 16: Cause of Failure: Normal Force Main Fitting broken out of the GFRP Composite in the Connection Tunnel for Outer Wing.



	Experimentally Established Strength Values for CFRP Cap and GFRP Web	Fig. 17
--	---	----------------



	Fiber Content Independent Spar Cap Strength Values $K_{\sigma dG}$ and Web Loading $K_{\sigma d\#}$	Fig. 18
---	--	----------------